



- MX-Proximity-Box
- 1 screwdriver
- 1 plug 3 to 5 mm
- 1 plug 5 to 7 mm
- 1 MxBus cable 0.5 m/1.64 ft
- 2 washers 4.3 mm dia.
- 2 stainless steel wood screws 4x40 mm
- 2 screw anchors S6
- 1 security bit TX10

Motion Detection with Radar Sensor Technology

Radar-based detection for any camera with MxBus connector

More information:

www.mobotix.com > Products > Accessories > Interface Boxes

MX-PROX-BOX
32.765-001_EN_03/2017

MOBOTIX

Connection Example

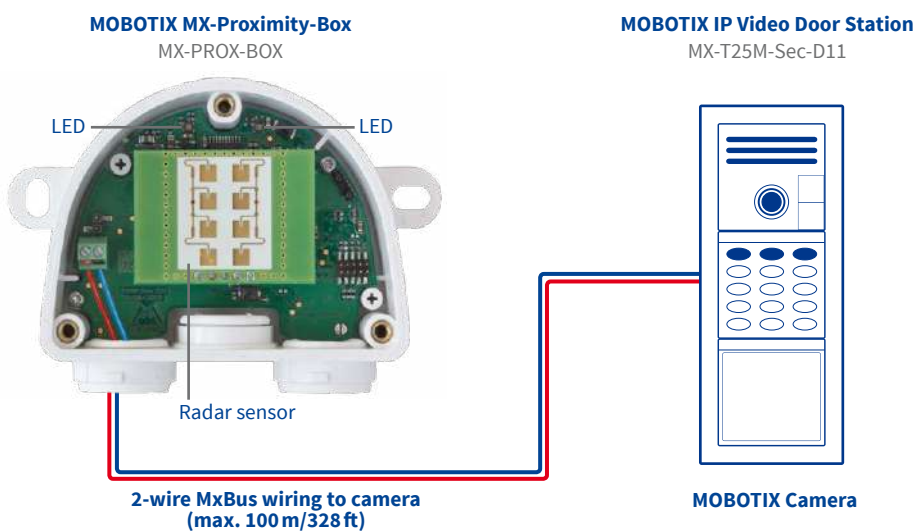

Installation Instructions

1. Find a good location for installing

Select the location for installing the device so that the objects you want to detect are within the detection area of the box (80° horizontally, 34° vertically). Note that the detection precision is best if the objects are moving perpendicular to the front label of the MX-Proximity-Box:

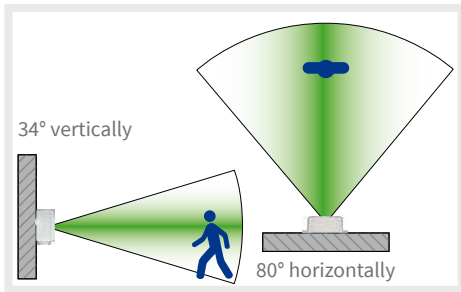

2. Suitable materials for concealed installation

This section is only relevant if you want to install the MX-Proximity-Box behind any materials.

It is not possible to install the MX-Proximity-Box behind some materials since they absorb or reflect the radar waves (e.g., metal or metal-coated surfaces). Other materials are better suited since they absorb radar waves only slightly (e.g., uncoated glass, plastics, various wood-based materials, drywall).

It is highly recommended to test the detection area before installing by covering the front of the MX-Proximity-Box with the material you want to use!

3. Attach the box

Attach the MX-Proximity-Box at the mounting position with the cable ports pointing downwards. Next, remove the three security screws of the box cover using the enclosed security bit TX10 and remove the cover.



4. Prepare the connection cables

Before proceeding, make sure there is no current on the MxBus wires!

Cut the MxBus wires to size (2-wire, 0.6–0.8 mm diameter). When using wires without sheath, strip the insulation of the wires for 5 mm and push the wires through the eight-wire plug (left).

When using a cable with jacket (e.g., J-Y(St)Y), remove the pre-installed eight-wire plug and insert the appropriate cable plug (3 to 5 mm or 5 to 7 mm). Press the rubber plug into the casing in such a way that the rims stick out equally on both sides. Push the cable through the plug, remove the sheath on a length of 15 mm/0.6 in and strip the insulation of the wires for about 5 mm/0.2 in.

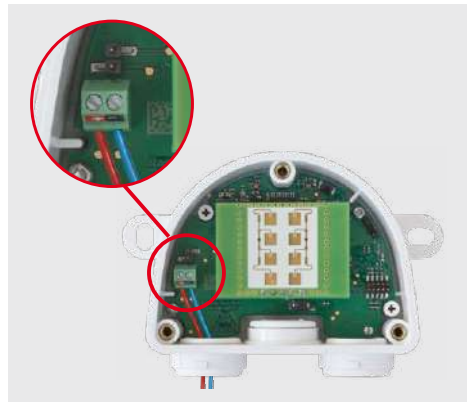

5. Connect the MxBus wires to the terminal

Connect the MxBus wires to the terminals of the MX-Proximity-Box using the screwdriver. Make sure to maintain the polarity (see sticker on the front of the terminal).

6. Mount the cover

Mount the cover back onto the MX-Proximity-Box and affix it using the cover screws.

7. Connect the MxBus wires to the opposite side

Connect the MxBus wires as described in the corresponding manual to the MOBOTIX camera or to another MxBus module connected to a camera (e.g. KeypadRFID, MX-DoorMaster). Make sure not to exceed the overall length of the MxBus wiring (max. 100 m/328 ft).



LED Signaling

Operating Status Radar Signal



- LED off
- LED permanently on
- ◐ LED blinking

| | LED | Meaning |
|-------------------------|-----|----------------------------|
| Operating status (left) | ○ | Not connected |
| | ● | Regular operation |
| | ◐ | Unencrypted communication |
| | ◑ | Error during communication |
| Radar signal (right) | ● | Leaving |
| | ◐ | Approaching |
| | ● | Movement |

The intensity of the LEDs varies depending on the strength of the reflected radar waves.

1. Open the MOBOTIX camera's user interface in the browser

- Enter the IP address of the camera that is connected to the MX-Proximity-Box in the browser (admin access rights required):

`http://<IP address of camera>`

2. Activate MxBus interface and MX-Proximity-Box

- Open the **Admin Menu > Hardware Configuration > Manage MxBus Modules** dialog.
- Make sure that the **MxBus Interface** is connected. If the interface is not connected, click on **Connect**.
- In the **Device** section, check if the MX-Proximity-Box line is set to **Active**. If this is not the case, click on **Refresh**.

3. Configure MX-Proximity-Box

- In the same dialog as in step 2, click on **MxMessageSystem Configuration**.
- Click on **Load configuration of connected devices**.
- Click on **Edit Messages**, then on **New message** and enter a suitable **Message name**.
- Click on the bar with the desired MX-Proximity-Box, then on **Add**.

- Select the **Message name**. The **Recurrence time** specifies the time to pause before the message can be sent again.

- In addition, you can select a movement profile for triggering events. The predefined **Approaching**, **Leaving** and **Movement** profiles combine the corresponding parameters. The **Custom** profile allows setting individual values for special purposes.
- In order to store the MX-Proximity-Box configuration, click on **Transfer entire configuration**.

4. Configure events

- Open the **Setup Menu > Event Control > Event Overview** dialog.
- In the **Message Events** section, click on **Edit** and create the profiles for message events as required (e.g., for starting a recording).

5. Store the camera configuration

- In the Live screen of the camera, click on **Admin Menu > Configuration > Store**, permanently store the camera configuration and reboot the camera.

Resetting the MX-Proximity-Box

If the MX-Proximity-Box had been connected to a different camera before and was not deactivated or reset before detaching, the left LED (operating status) may flash red after establishing the connection. In this case, you need to reset the connected and activated MX-Proximity-Box to **factory defaults**:

- Remove the box cover.
- Bridge the contact surfaces in the bottom right corner (red circle in figure) using a screwdriver, for example (both LEDs are flashing red/blue with increasing frequency).
- Only remove the bridge if both LEDs of the MX-Proximity-Box are flashing green on/off 3

times to indicate that the process has finished successfully.

- Mount the cover back onto the box.
- Set up the MX-Proximity-Box in the camera (see «Initial Operation of the MX-Proximity-Box»).



Safety Warnings

- This product must not be used in locations exposed to the dangers of explosion.
- Make sure that you install this product as outlined in the installation instructions above.
- The MOBOTIX MX-Proximity-Box is to be used only for detecting movements using radar sensors in IP66 environments.
- Electrical systems and equipment may only be installed, modified and maintained by a qualified electrician or under the direction and supervision of a qualified electrician in accordance with the applicable electrical guidelines. Make sure to properly set up all electrical connections.
- Make sure that you adhere to all relevant laws, regulations and that you fulfill all certification requirements for the intended use.

- Torque for all screws: 0.4 Nm.
- Press the white cable plug (eight-wire plug or cable plug 3 to 5 mm or 5 to 7 mm) into the casing in such a way that the rims stick out equally on both sides.
- Make sure to use only twisted-pair cabling (e.g., **J-Y(St)Y**) for MxBus wiring.
- The length of the entire MxBus wiring must not exceed 100 m/328 ft.
- Diameter of all wires: 0.6–0.8 mm (0.8 mm = AWG 21 recommended to reduce line losses).

Technical Specifications

| MX-Proximity-Box | |
|--|---|
| Connection | MxBus (2 terminals) |
| Power Supply | 48 V DC (via camera and MxBus) |
| Power consumption | 0.5 to 1 W |
| Frequency (radar signal) | ~24 GHz |
| Operating Conditions | IP66 (DIN EN 60529) -20 to +60 °C/-4 to +140 °F |
| Dimensions (height x width x depth) | 63 x 87 x 30 mm/2.48 x 3.43 x 1.18 in |
| Materials | Housing: PBT GF30 |
| Weight | Approx. 75 g/0.17 lb |
| Detection area | Persons: 0 to max. 15 m/16.40 yd; cars: 0 to max. 35 m/38.28 yd |
| Concealed installation | Possible behind materials with low absorbability of radar waves (e.g., uncoated glass, plastics, various wood-based materials, drywall). It is highly recommended to test the material before installing! |
| Further Information regarding detection | Detectable movements: Approaching, leaving and general motion detection |

Drilling Template

Drilling templates for other MOBOTIX components:
www.mobotix.com > Support > Manuals

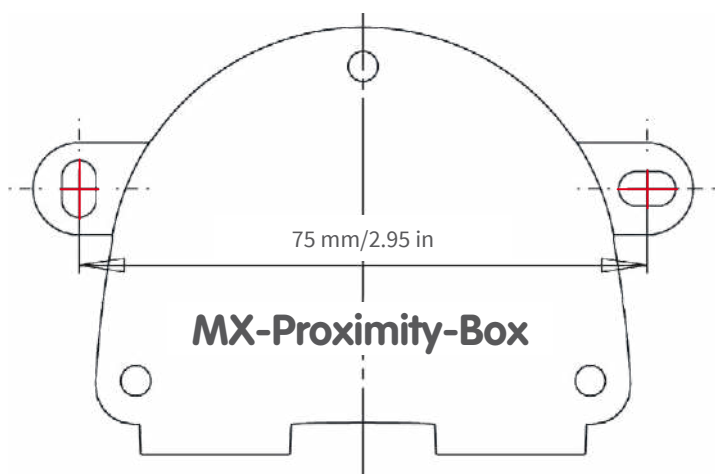

This device is granted pursuant to the Japanese Radio Law (電波法)
This device should not be modified (otherwise the granted designation number will become invalid)

MOBOTIX, the MX logo, MxControlCenter, MxEasy, MxPEG and MxActivitySensor are trademarks of MOBOTIX AG registered in the European Union, the U.S.A., and other countries • Information subject to change without notice
• MOBOTIX does not assume any liability for technical or editorial errors or omissions contained herein • All rights reserved • © MOBOTIX AG 2016

MOBOTIX AG
Kaiserstrasse
D-67722 Langmeil
Phone: +49 6302 9816-103
Fax: +49 6302 9816-190
sales@mobotix.com
www.mobotix.com